

OPEN ACCESS

Review—Thermal Safety Management in Li-Ion Batteries: Current Issues and Perspectives

To cite this article: Rengaswamy Srinivasan *et al* 2020 *J. Electrochem. Soc.* **167** 140516

View the [article online](#) for updates and enhancements.

239th ECS Meeting

with the 18th International Meeting on Chemical Sensors (IMCS)

ABSTRACT DEADLINE: DECEMBER 4, 2020



May 30-June 3, 2021

SUBMIT NOW →



Review—Thermal Safety Management in Li-Ion Batteries: Current Issues and Perspectives

Rengaswamy Srinivasan,^{1,*} Plamen A. Demirev,¹ Bliss G. Carkhuff,¹
Shriram Santhanagopalan,^{2,*} Judith A. Jeevarajan,^{3,*} and Thomas P. Barrera⁴

¹The Johns Hopkins University Applied Physics Laboratory, Laurel, Maryland 20723, United States of America

²Center for Integrated Mobility Systems, National Renewable Energy Laboratory, Golden, Colorado 80401, United States of America

³Underwriters Laboratories, League City, Texas 77573, United States of America

⁴LIB-X Consulting, Long Beach, California 90803, United States of America

Approaches for thermal management of lithium-ion (Li-ion) batteries do not always keep pace with advances in energy storage and power delivering capabilities. Root-cause analysis and empirical evidence indicate that thermal runaway (TR) in cells and cell-to-cell thermal propagation are due to adverse changes in physical and chemical characteristics internal to the cell. However, industry widely uses battery management systems (BMS) originally designed for aqueous-based batteries to manage Li-ion batteries. Even the “best” BMS that monitor both voltage and outside-surface temperature of each cell are not capable of preventing TR or TR propagation, because voltage and surface-mounted temperature sensors do not track fast-emerging adverse events inside a cell. Most BMS typically include a few thermistors mounted on select cells to monitor their surface temperature. Technology to track intra-cell changes that are TR precursors is becoming available. Simultaneously, the complex pathways resulting in cell-to-cell TR propagation are being successfully modelled and mapped. Innovative solutions to prevent TR and thermal propagation are being advanced. These include modern BMS for rapid monitoring the internal health of each individual cell and physical as well as chemical methods to reduce the deleterious effects of rapid cell-to-cell heat and material transport in case of TR.

© 2020 The Author(s). Published on behalf of The Electrochemical Society by IOP Publishing Limited. This is an open access article distributed under the terms of the Creative Commons Attribution 4.0 License (CC BY, <http://creativecommons.org/licenses/by/4.0/>), which permits unrestricted reuse of the work in any medium, provided the original work is properly cited. [DOI: 10.1149/1945-7111/abc0a5]



Manuscript submitted May 26, 2020; revised manuscript received September 20, 2020. Published October 22, 2020.

The revolutionary impact of Li-ion batteries on the overall world economic and technical development has been recognized with the 2019 Nobel Prize for its inventors. Li-ion batteries are rapidly becoming the main component in energy storage and power delivery systems for electrical grid and fossil-fuel free electric vehicles (EV). The production rate of Li-ion cells is accelerating, as is their use in small consumer electronics devices (smart phones, tablets and computers), electrified transportation (EV) and large energy storage systems (power grid). A constant growth in global Li-ion battery production is anticipated over the next decade, with projections varying from four-fold to ten-fold increases (Fig. 1).¹

Advances in materials properties to increase specific energy and power delivery capabilities of this technology promise to further expand its uses.^{2,3} In parallel, it has been recognized that continued work is required to improve Li-ion battery safety during their entire life-cycle—from manufacturing through operation to resource recycling.⁴⁻⁷ Two underlying phenomena contributing to Li-ion battery instability, which may decrease their thermal safety, are thermal runaway (TR) in an individual cell and cell-to-cell thermal propagation. TR occurs in a single cell, and if not localized it can result in TR propagation in a multi-cell battery.⁸ TR propagation can lead to deflagration, rupture and venting with severe consequences to equipment and users.⁹ Battery thermal management is one important aspect in improving the overall safety of the technology.¹⁰⁻¹⁹ The principal goal of thermal management is to predict, prevent and, if required, mitigate the two main thermal energy effects in Li-ion batteries - TR and cell-to-cell TR propagation.

Thermal safety can be improved through clearer understanding of the physicochemical properties of the Li-ion system, and the conditions necessary to maintain system stability. These inherent instabilities can be traced to the complex components that constitute each Li-ion cell in a battery. Extensive efforts have been dedicated to obtain a better interpretation of thermal safety using a variety of mathematical and computational models. These include elaborate deterministic models for the individual reactions that take place

inside the cells before venting and TR,²⁰ computational fluid dynamics (CFD) simulations of cell-design and packing architectures in multi-cell solutions,²¹ flammability limits²² and high-throughput screening studies linking material-level signatures to system level responses.²³ Similarly, at the systems level, sensor fault detection using parameters regressed to circuit models,²⁴ data-driven approaches that quantify probability of failure accounting for mean-time-between-failures,²⁵ risk assessment through Failure Mode Effects Analysis or similar methods,^{26,27} cloud-based fault diagnostics tools,^{28,29} and regression of trends from databanks that span different cell-formats and chemistries,³⁰ have been investigated. Some of the key challenges in predicting the onset of TR include extremely low frequency of its occurrence in the field; lack of a consistent definition³¹ for “Thermal Runaway,” resulting in mismatch between lab-scale test results and field events; wide variability in test results; limited set of relevant experimental results to validate and parameterize the models; and significant budget increases for testing with growth in the size and complexity of battery test articles. As a result, pattern identification methods such as machine learning³² or big data analysis³³ have access to limited size training data sets (e.g., cycle-aging or calendaring degradation data collected over several months and safety data collected over a longer time) to yield sufficient confidence in the results. On the other hand, even after carefully controlling for test-setup and operator variability, the outcome of mechanical abuse test results (e.g., a nail penetration test) are not always deterministic.³⁴ In such instances, analyzing the sensitivity of system-level test results to specific design parameters³⁵ has been demonstrated to be useful. The confidence-intervals for the parameters obtained from such experiments can subsequently be used as input to mathematical models and to build safety-maps that show the interplay of probabilities-for-failure derived from each parameter (Fig. 2).^{36,37}

Another notable gap in employing simulations to understand battery safety is the absence of an “integrated approach” to help understand experimental characterization performed at different scales. For instance, there are independent experimental measurements correlating differential scanning calorimetry (DSC) results at the component-level with accelerating rate calorimetry (ARC) at the cell level.^{38,39} Similarly, mathematical models that study the effect

*Electrochemical Society Member.

²E-mail: rengaswamy.srinivasan@jhuapl.edu

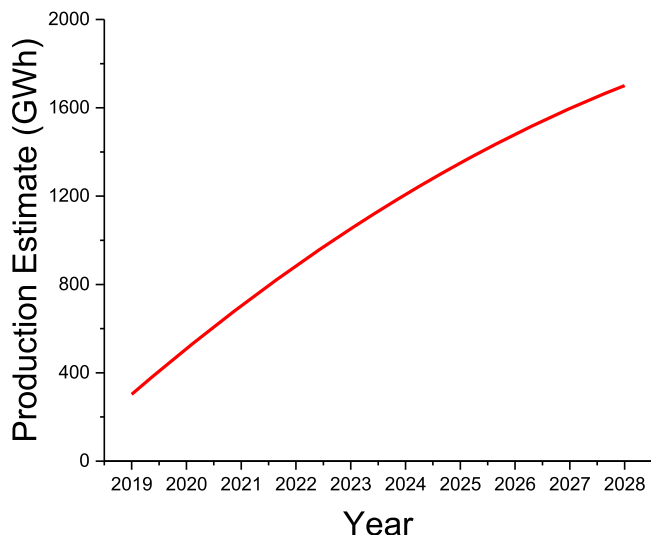

Figure 1. Anticipated growth in lithium battery global production (total energy capacity) over the next decade.

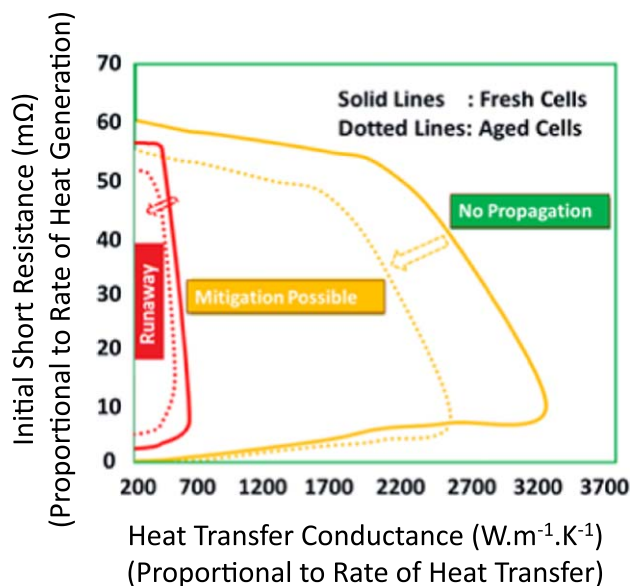

Figure 2. Mathematical models help construct generic “safety maps,” using test data from the module levels to design virtual battery packs with different configurations and to compare propensity for propagation. Combined with cell ageing data, these maps can be used to track how the threshold for propagation changes with the life of the battery [adapted from Ref. 36].

of varying the spacing between cells have been developed. However, mathematical models that combine the DSC and ARC results together with other heat-transfer experiments to determine optimal spacing between cells in a module or designing vent paths for battery packs have not been explored. In analogy, stability of different transition metal oxides and associated oxygen release have been studied separately, using mathematical models²² and in experiments.⁴⁰ Combining these results with a CFD model at the cell-scale or higher⁴¹ will enable concurrent evaluation of materials limitations alongside engineering constraints.

Discussion

Lithium-ion battery management parameters include electrical energy, electrical power and thermal energy. Most battery management systems (BMS) manages the electrical power and energy through voltage and current sensors, and not through resistance or

impedance of the anode, cathode and the electrolyte. Thermal management in most BMS is through thermocouples, thermistors and similar sensors mounted outside the cells. Here we discuss current ongoing efforts in thermal management of Li-ion batteries including sensors and methods for direct measurement of the cell’s internal temperature (T_{int}).

Thermal management in Li-ion systems.—Thermal management is important for Li-ion systems since the stability of the high-energy density electrodes depends closely on the local temperature within the cell and its effects on the volatile organic solvents in the electrolyte. Some solvents have a boiling point as low as 90 °C and increases in T_{int} above 90 °C would boil off the solvent, increase the cell’s internal pressure, and force the solvent to vent. Therefore, preventing excessive rise in T_{int} should help preserve cell integrity.

Several authors have conducted detailed studies on mathematical modeling^{42,43} or performed measurements⁴⁴ to address thermal issues in small and large battery packs. Several of these studies highlight the implications of poor thermal management on the normal operation and lifetime of these batteries,^{45–47} as well as on safety aspects. We recently reported that for approximately every 13 °C increase in operating temperature, the lifespan of the battery is roughly reduced by 50%.⁴⁸ There have been similar reports on decreased performance under cold operating conditions.⁴⁹ These changes in lifespan are accompanied by increases in cell internal resistance. Coupled with the loss in cycling efficiency and power-generating ability, excessive heat generation under increased internal resistance accentuates safety concerns. These unsafe thermal situations are currently addressed by “management blocks” consisting of heating loops and cooling loops, and a “regulating” section that attempt to keep the battery surface temperature within a preset temperatures range. A description of integration between a battery management system and a thermal management block is provided elsewhere.⁵⁰ The thermal management unit inputs ambient and battery temperatures into smart controls that initiates cooling or heating during normal operation or sends emergency signal to ECU when abnormal fluctuations in temperatures are identified. The thermal management hardware, at a minimum, consists of fans and heaters. Several studies have explored more complex heating and cooling approaches that improve the overall coefficient of performance for the thermal management system.⁵¹ Others have favored simplicity of the hardware.⁵²

From a safety perspective, isolation (mechanical, thermal as well as electrical) between sub-units (cell-bricks or modules) and access to a thermal sink are key criteria used in battery-pack design. Avoiding leaks in liquid cooled systems, and arc-flash hazards in high-voltage units have been routinely addressed in several safety standards.⁵³ Almost all electric vehicle battery packs have dedicated vent ports to channel the gaseous effluents following a cell-venting event along preferred pathways, away from propagating to adjacent cells. Some battery modules include a phase-change material either in packaging or as part of the cell component. A key to successful mitigation of excessive temperature rise is the ability to dissipate the heats away from the cells.

Thermal management technologies^{42–53} are some examples of ongoing efforts that attempt to ensure thermal safety in Li-ion batteries. Despite these concerted efforts, Li-ion batteries continue to experience TR, TR propagation and deflagration. Some of the continuing safety issues with Li-ion batteries can be traced back to the evolution of BMS employed initially in aqueous battery management.

Battery management system types.—Within the constraints of limited existing databases, increasing demand and production, sufficiently advanced BMS for ensuring thermal safety and electrical efficiency must be built around every Li-ion battery. Due to their limitations, BMS designs and concepts based on previously-developed battery types do not improve the safety of current Li-ion batteries, and for some designs could even be reducing safety

margins. Understanding the physicochemical processes in Li-ion cells provides better perspective on failures in Li-ion batteries, including deflagration and other heat-induced failures.^{54,55} Deficiencies in BMS designs applied to current Li-ion technology can be traced back to designs for batteries containing nonflammable components, e.g., aqueous electrolytes.^{56,57} Most aqueous electrolyte rechargeable battery systems do not require specialized BMS. Charge-discharge management of rechargeable aqueous Ni-battery technologies such as nickel-cadmium (NiCd), nickel-hydrogen (NiH₂) and nickel-metal hydride (NiMH) cells is necessary to maximize performance while minimizing life-degradation.⁵⁶ To meet these requirements, charge control systems for aqueous Ni-batteries typically monitored battery temperature, voltage and current to estimate battery state-of-charge (SoC). More commonly, amp-hour integration was used to support recharge ratio charge control methods in high-reliability aerospace NiCd and NiH₂ battery applications.^{58,59} Pressure-based charge control methods were unique to NiH₂ batteries due to the characteristic quasi-linear change in H₂ pressure with SoC during charge-discharge cycling. In NiMH and NiCd batteries overcharging can generate hydrogen and oxygen gases, therefore voltage and temperature readings were used to limit overcharging; some degree of low-rate overcharge was typically used for NiCd and NiH₂ batteries to reduce self-discharge and prevent drop in SoC with cycling.⁶⁰ The thermal control system in those batteries was a resettable thermal fuse invented in 1939,⁶¹ (positive or negative thermal coefficient, PTC- or NTC-fuse,⁶² in today's terminology), located in the positive and negative leg of the series string of cells. Some control systems in NiMH and NiCd batteries had thermistors in specific locations to stop charge or discharge when the battery experienced sudden increases in temperature due to internal faults. Voltage limits were adjusted during charging to facilitate cell-level thermal dissipation to battery thermal control surfaces, in order to minimize thermal stress and improve battery life. The success of temperature-compensated voltage charge control methods used in NiCd batteries was adopted by NiH₂ batteries for applications such as the NASA Hubble Space Telescope and International Space Station.^{63,64}

In another aqueous system example, lead acid batteries can fail due to self-discharge and electrolysis of the acid leading to hydrogen gas generation. Hence, BMS (more accurately: control system incorporated in the charger and not the battery) in lead acid batteries are designed to maintain the voltage at a prescribed level during the standby periods, and to maintain "float charge" to prevent battery self-discharge, "dry-out" failures and internal shorts. The problems found in aqueous batteries (such as lead-acid, NiCd, or NiMH) were far different from Li-ion batteries, therefore requiring a different set of design solutions needed for their control systems. The aqueous systems were not designed with dedicated BMS internal to every cell in a battery; the above-mentioned controls were incorporated in individual components as controls within the battery charger. Adapting such controllers as BMS for Li-ion batteries has been insufficient to solve the more complex problems found in these batteries. Yet, most modern BMS for Li-ion batteries continue to rely only on sensors for battery voltage (and cell voltage in a few cases) and surface-mounted temperature sensors.^{16,65–67} Even as the modern-day BMS use advanced mathematical models to predict internal states of cell, several authors emphasize the need to modernize BMS sensors, use of improved impedance-based sensors,^{16,65,67} and internal temperature sensors.^{16,66}

Root causes of thermal runaway in Li-ion batteries.—The inherent instability of the Li-ion battery system can be traced to the complexity in the components that constitute each Li-ion cell. At 200 Wh kg⁻¹, a Li-ion cell's energy density by weight is approximately one-quarter of that for gunpowder or one-tenth for dynamite; however, only Li-ion cells are capable of releasing energy at controlled rates, including start-and-stop on command, as required by the user. In Li-ion cells, tens of individual components work in concert to store a large amount of energy in the smallest possible

mass and volume and deliver energy over a range of desired rates. Even though the physicochemical properties of those individual components are fairly well cataloged,^{20–30,35–40} their combined behavior is not.^{31–34} Catastrophic failure in Li-ion batteries can be induced as a result of electrical, mechanical and thermal abuse conditions.^{10,68} Historically, these three types of abuse have been detrimental to the safety of all battery types, including classical aqueous ones. In general, a battery must not be over-charged and over-discharged, subjected to extreme compression, vibration or shock, or heat. Most Li-ion batteries manufactured today are designed with protections against those three types of abuse conditions. Despite engineering designs that protect them from extreme mechanical, electrical and thermal abuse, Li-ion batteries can still experience TR and deflagration, indicating that multiple factors need to be considered to improve battery safety. For example, inadvertent inclusion of foreign or native object debris (FOD or NOD) as well as manufacturing defects can contribute to creating cell internal short pathways. Although implementation of sophisticated quality control methods and cell screening protocols have been successfully implemented to control FOD, NOD, and manufacturing defects, undetected latent defects may contribute to a cell internal short hazards.⁶⁹ Nevertheless, TR resulting from cell internal shorting continues to occur, therefore quality control and cell screening, though essential, is not sufficient to prevent TR. Dendrite growth during charge-discharge in a Li-ion cell and cell component ageing at different rates can lead to TR as well. While there is paucity of data on the association between failure in an individual cell component and cell failure, premature cell failure commonly results in battery failure.

Implementing thermal safety from design to disposal.—Steps to ensure thermal safety start with battery design, extend into its entire operational life, and end only when the battery is safely disposed.⁷⁰ From design to disposal, improved Li-ion battery safety can be implemented in four major practical steps broadly indicated as follows. Step 1 in designing a safe battery starts with screening, selecting and matching cells to be used in manufacturing the battery. Step 2 is to ensure operation of every cell in the battery within preset limits of voltage and temperature. Step 3 is to predict and prevent TR in an individual cell within the battery. The final step, Step 4 is to prevent cell-to-cell propagation of TR, even if one cell in the battery experiences TR. Details associated with the practical realization of each of these four safety steps are far more important in manufacturing of Li-ion batteries than in aqueous batteries. For aqueous batteries, the last two steps are not even applicable. In aqueous batteries, improper procedures associated with the first two steps do not result in fire, while in Li-ion batteries, they may cause TR and fires. Implementing the first two steps in Li-ion battery manufacturing requires a level of rigor not found in today's screening and matching practices, and failure resulting from poor implementation is far less forgiving than in aqueous batteries.

Matching individual cells in a battery.—The best practice in screening and matching aqueous-based battery cells includes identifying cells with same nameplate (product batch) information and matching them based on test data for cell voltage and Ah capacity through charge-discharge cycling.⁶⁸ Obviously, matching cells based on nameplate information and test data is a best practice for both aqueous and Li-ion batteries. However, voltage and amp-hour capacity matching do not guarantee that Li-ion cells are matched at the level of their internal components, namely electrolyte, anode and cathode. Problems that might arise from not matching the cells at a component level are illustrated through a common practice known as cathode-limited or anode-limited cell design.⁵⁶ For example, a cathode-limited cell is designed with excess anode material, so that when a cell is fully discharged, only the cathode is completely consumed, leaving some unreacted electroactive material at the anode, preventing unintended oxidation of the current collector at the anode. By extension, if the electrolyte resistance (R_s)

for each cell is not matched between the cells, then during charge and discharge, the cell with the highest R_s would experience an increased internal voltage drop and reach the preset voltage limits sooner than the rest of the cells. In a battery with dissimilar R_s in multiple cells, all those cells will experience dissimilar depth-of-discharge (DOD), therefore inducing dissimilar cycle life ageing. More detrimental than not matching R_s of individual cells is not matching their individual cell anode impedance (Z_a) and cathode impedance (Z_c). When current passes through a cell, the temperature inside a cell is not uniform, but differs for each component, because the respective R_s , Z_a and Z_c are different.⁷¹ If cells are not matched individually for R_s , Z_a and Z_c , then there will be a difference in the temperatures of the mismatched components. For example, if a specific cell is not matched for Z_a with the rest, that cell will be subjected to a different anode temperature during charge-discharge, potentially resulting in that cell's anode aging at different rates from the rest of the cells. Over multiple charge-discharge cycles that anode may fail prematurely and that could lead to TR. In turn, premature cell failure commonly results in battery failure. We have argued that internal temperature monitoring is a viable path to identify thermally malfunctioning cells within a battery.⁵⁴ Managing cell-to-cell temperature balancing in electric vehicles is also discussed.¹⁶ The practice of maintaining isothermal conditions varies between industries. For example, requirements to control temperature gradients within 2 °C–5 °C is common for space qualified Li-ion battery applications.⁷²

The current flowing through the battery would cause similar changes in the concentration of the active materials at the anode and the cathode through most cells, only the cell with mismatched Z_a or Z_c could be forced into over-discharge or over-charge at the anode or the cathode. In aqueous batteries, if a cell in series is over-discharged, then the resulting voltage reversal will increase the internal resistance of that cell and the battery will stop functioning. In Li-ion batteries, voltage reversal can subsequently lead to a catastrophic failure leading to TR, TR propagation, fire and deflagration. For example, Li-ion cell over-discharge may lead to the dissolution of copper (from the anode current collector) which deposits as copper metal on the cathode, anode and separator during subsequent charging. Continuous over-discharge and charge cycling leads to plating of copper metal on graphite, which blocks lithium from intercalating into graphite and lithium metal deposition on top of the copper layer.⁷³ Lithium metal deposits as dendrites, following laws of "diffusion limited aggregation."⁷⁴ Dendritic deposits can form sharp, strong and needle-like structures, capable of piercing through polymer separators. Inside Li-ion cells, dendritic lithium metal deposits create electrical short circuit pathways between the anode and cathode, leading to rapid onset of TR.⁵⁶ Therefore, the practice of matching cells for voltage and Ah capacity adequate for aqueous batteries is necessary but not sufficient for Li-ion batteries. The goal of successful Li-ion cell matching is to ensure uniform DOD, aid uniform aging, prevent cell polarity reversal, overheating, etc.; therefore, matching should also include monitoring of Z_c , Z_a and R_s values for individual cells.

In a Li-ion cell, the impedance of each of its components, namely, Z_c , Z_a and R_s is uniquely dependent on frequency (frequency range).⁷⁵ Therefore, cell impedance matching only at 1 kHz cannot successfully match every component of every cell. More importantly, since the frequency that corresponds to every component is uniquely dependent on each cell model, measuring impedance at 1 kHz cannot accurately map Z_c , Z_a or R_s in every cell model. In order to improve thermal safety, every Li-ion cell in a battery should be matched for Z_c , Z_a and R_s at different frequencies, in addition to cell voltage, Ah-capacity, make, model, date of manufacturing and lot number as stated in Ref. 70. In a battery containing cells with matched impedance components Z_c , Z_a and R_s (in addition to cell capacity), the cells tend to age uniformly, reducing the probability of an individual cell ageing prematurely (see Fig. 4 and 6 in Ref. 54).

Monitoring of cell internal temperature, voltage, state-of-charge and state-of-health during charging and discharging.—

The second step in safety design is ensuring that every cell in the battery is operated within preset limits of voltage and temperature. This step is commonly implemented through BMS, initially developed for cell monitoring and control in aqueous batteries.^{63,64} In aqueous batteries, temperature monitoring was not necessitated by the possibility of TR, but to prevent the electrolyte from freezing or evaporating. In those situations, monitoring the temperature of the battery's environment was considered adequate, therefore, placement of one or two thermal sensors per battery on the inner- and outer-wall of the battery became a common practice. Unlike aqueous batteries, thermal management in Li-ion cells requires one thermal sensor per cell. That thermal sensor should be capable of measuring or estimating the internal temperature (T_{int}) of each cell. There are multiple reasons to monitor T_{int} of every cell. TR can be caused by rising temperature inside the cell. At temperatures as low as 85 °C, the solid-electrolyte-interface (SEI) layer starts breaking down, generating exothermic reactions between the graphitic carbon anode and the carbonate esters in the electrolyte. If the temperature is increased further, the organic esters would convert to vapor,⁷⁶ and the increased pressure inside the cell will be sufficient to cause venting.^{77,78} When the cell vents, it will disperse flammable organic solvents throughout the battery compartment and deposit them on the surface of adjacent cells.⁵⁵ From the breakdown of the SEI to venting, each process is detrimental to battery safety. Most serious are the consequence of T_{int} increasing above 155 °C, when cascading irreversible exothermic reactions proceed inside the cell, i.e. TR.²⁰ Every reaction leading to TR is associated with a rise in the cell's internal temperature. Therefore, monitoring T_{int} is the most efficient way to conduct battery management and improve battery safety.

Until a decade ago, technology to directly measure T_{int} in Li-ion cells was not developed. In 2011, Srinivasan et al. first demonstrated a technique to monitor T_{int} in Li-ion cells at rest⁷⁹; subsequent research extended the technique to monitor T_{int} under dynamic conditions of charge and discharge^{71,80}; and more recently in multiple cells present in series-parallel combinations in batteries.⁵⁴ This technique is non-invasive, does not require additional wiring other than the pairs already used in cell-voltage monitoring, and its implementation in BMS is straightforward. Diverse aspects of the impedance-based sensor for T_{int} monitoring and thermal management have been discussed in detail by several authors.^{81–86} In many commercial BMS, T_{int} is still estimated by combining external temperature monitoring and thermal modelling.⁸⁷ Such mathematical models require a separate construct for each Li-ion cell type, because cell's internal characteristics are manufacturer dependent. Aside from the need for intensive computation capabilities, to be accurate, these models require data input from multiple sensors per cell.^{81,88} Furthermore, thermal inertia causes a delay in heat transfer from a cell interior to its exterior, therefore, external sensors never provide real-time T_{int} data.⁷¹ Ideally, a safety-centric BMS should employ sensors that directly measure T_{int} .

SoC monitoring during charging and discharging remains most challenging when analyzing the internal state of a Li-ion cell. Coulomb counting is perhaps the best available approximation to SoC estimation,⁸⁹ which is limited by reduction in charge storage capacity (Ah-capacity) of a cell with cycle life and calendar life. An accurate tracking of SoC requires periodic recalibration of capacity loss with time. Impedance techniques for SoC monitoring are virtually ineffective: a cell's impedance is far more sensitive to its internal temperature, T_{int} than SoC.⁷¹ SoC estimation through cell-voltage (E_{cv}) measurements is limited by the slow diffusion of lithium cations (Li^+) as they lithiate and delithiate the anode and cathode, respectively. The diffusion rate-dependency of E_{cv} is further complicated by the temperature dependence of E_{cv} on the entropy of intercalation of Li^+ and the temporal changes in T_{int} during charging and discharging.^{71,80} Therefore, measuring E_{cv} has remained far from a reliable technique to monitor SoC. State-of-health (SoH) monitoring of Li-ion cells under dynamic conditions is

as challenging as SoC monitoring. The use of impedance to monitor SoH⁹⁰ is complicated due to changes in Li⁺ concentration of the electrolyte during charging and discharging.⁵⁴

There is a gap between BMS systems currently deployed for SoC and SoH monitoring and the understanding of complex physico-chemical processes during charging and discharging of Li-ion cells. Novel BMS designs that account for these processes are required to improve the thermal safety in Li-ion batteries.

Cell venting prior to TR.—The third step in safety-centric BMS design is related to predicting or preventing individual cell venting. The prevailing opinion is that with increasing T_{int} a cell vents only when it ejects energetic materials during TR.⁵⁶ In fact, a cell can initially vent before it experiences TR in a process termed pre-TR venting that deposits combustible organic material on other cells inside the battery compartment.⁵⁵ Subsequently, the cell vents again during the actual TR igniting the solvents deposited following the first venting, initiating TR in additional cells. Therefore, combustion inside a battery occurs only during TR at multiple battery locations, i.e. cell-to-cell TR propagation is taking place. Neither of the BMS currently in use can prevent TR or cell-to-cell TR propagation.

In a recent study,⁵⁵ the temporal profiles of the processes during cell venting upon heating were recorded by an array of instruments, including online Fourier transform infrared and hyperspectral imaging techniques. Preceding the actual TR event, the cell ejected gaseous alkyl carbonate esters at about 100 °C in a “pre-TR vent.” Minutes later, TR occurred, and the cell vented gaseous CO, CO₂, HF, and oxides of cobalt, manganese and lithium, along with solid nickel oxide. Organic solvents were not detected in the TR ejecta. The temperature of the TR ejecta was initially at 1500 °C, and dropped to 600 °C in about 50 ms. Off-line chemical analysis by gas chromatography-mass spectrometry of the vented gases, and gravimetry of the pre-TR vented matter provided additional information on the reactions during pre-TR venting and TR propagation.⁵⁵

Pre-TR cell venting disperses flammable organic solvents inside the battery housing. In fact, the thermal energy of the ejecta during TR is less than the energy of pre-TR ejecta that can be released when they are burning.⁵⁵ The flammable solvents released as gases during pre-TR venting are deposited as a liquid on top of adjacent cells. When they combust, they burn not at the cell that vented it, but on top of adjacent cells in the battery. Combustion of the pre-TR ejecta can be initiated by an arc, spark or hot-spot and supported by oxidizers ejected during the TR. Thus, TR propagation does not occur at the time of pre-TR venting, because the required spark and oxidizers become available only during TR. Fernandes et al. also demonstrated that overcharging of a Li-ion cell initiated pre-TR venting.⁹¹ Through in situ continuous analysis of the vented gases they recorded the time-dependent changes in the concentrations and constituents of the chemicals. Their test data also confirmed that the majority constituents of the pre-TR vent gas were flammable volatile solvents.

Resolving the temporal characteristics of pre-TR venting and venting during TR, and spatial differentiation between the locations of the combustion of the pre-TR- and TR-vented materials are critical in designing a safety-centric BMS to prevent TR and cell-to-cell TR propagation. Most importantly, pre-TR venting occurs before TR reactions start, which means that if the increase in T_{int} is successfully stopped before the pre-TR venting, then the cell would not go into TR. We demonstrated recently that changes in cell impedance (Z_{cell}) can be measured tens of seconds before the pre-TR venting.⁹² Cell impedance values are dependent on the frequencies at which they are measured. For example, in LG HG2 and Samsung SDI-26F 18650 cells, changes in impedance before the pre-TR venting are detectable at frequencies less than 10 Hz. In 18650 cells, impedance measured using a 1 kHz signal does not carry any information on the changes in Z_{cell} caused by structural changes inside the cell, especially at high temperatures (>85 °C). Surface-mounted temperature sensors may provide evidence to the actual pre-TR venting event, but carry little information on gas generation

that occurs before the pre-TR venting. If a BMS monitors a cell's internal impedance at a frequency less than 10 Hz, it should be able to predict and counteract pre-TR venting and TR. Currently, no commercial BMS performs real-time monitoring of a cell's internal impedance, therefore pre-TR venting cannot be predicted by such a BMS. Since generated gases do not exit the cell until after the pre-TR venting, gas sensors can only identify the event after gases have vented; that may be too late to counteract subsequent TR.

Cell-to-cell TR propagation.—The fourth step in providing thermal safety is preventing cell-to-cell propagation of TR, even if one cell in the battery undergoes TR. Some Li-ion batteries are designed to remove ejecta quickly from the cell experiencing TR through vent channels, which should prevent propagation. A streamlined ejecta channel capable of removing the fast-moving energetic ejecta should prevent its impact on the rest of the cells inside the battery compartment. In fact, computational fluid dynamics and thermal modelling show that even a well-designed vent channel may not always prevent TR propagation.⁵⁵

With current commercial BMS not capable of counteracting cell TR, and vent channels unable to stop propagation, new and radical solutions are needed to prevent cell-to-cell thermal propagation, fire and deflagration. Until then, Li-ion battery designers and manufacturers should strive for cell matching based on anode, cathode and electrolyte impedance, internal cell temperature monitoring, and identifying and counteracting pre-TR venting that leads to flammable gas release.

Towards an intelligent BMS.—Fluctuations in power demands range from a few W in smart phones to kW in EV to hundreds of kW in power grids. Although there is no direct evidence that power fluctuations can cause battery failure, battery-induced power failures and fires are common among power grids and in EVs.⁹ Such failures and fires, and even unscheduled downtime caused by premature ageing in the battery cells, can be costly. Even BMS with advanced functionalities⁵⁴ may not be sufficient to ensure cost-effective use of Li-ion batteries in EVs and power grids. To prevent power failures and to improve the cost of operations and maintenance, the BMS should be far “smarter” and capable to work in conjunction with “intelligent” power routing devices (iPROUD). That was a core goal of the 2012 Advanced Management and Protection of Energy Storage Devices (AMPED) program sponsored by the US Department of Energy.⁹³ A decade later, such a goal still remains open.

A schematic of a BMS-iPROUD concept is shown in Fig. 3.⁹⁴ In this example, the role of the iPROUD is to receive information not just from the BMS, but from the load as well as the power grid through two-way communication channels.

The goal of the iPROUD device is to regulate the rate at which the battery receives and stores energy from the grid, and the rate at which the battery supports the load. The BMS, with sensors for the internal state (voltage, temperature, impedance, etc.) of each cell, monitors and manages every cell in the battery, and inputs these data into the iPROUD. It uses the data to relate the internal state of every cell to the functional capabilities of the battery and combines the data with information it receives from the load to decide on the level of power-support available from the battery. It makes similar decisions on the grid-to-battery interactions. If the BMS detects an abnormal internal state for any cell in the battery, then the iPROUD will not allow charging the module with the abnormal cell until the cell's state returns to normal. One example—“fast-charging” a battery while using the cell's internal temperature to make charging decision—is shown in Fig. 4.

Fast battery charging is not only a matter of convenience in EVs, it can be essential in power grid applications as well. It is also an operational parameter that could increase the cell internal temperature, potentially accelerating aging and driving it into TR and venting. Attempts to use surface temperature as a parameter to safeguard cells from venting are potentially misleading and thus

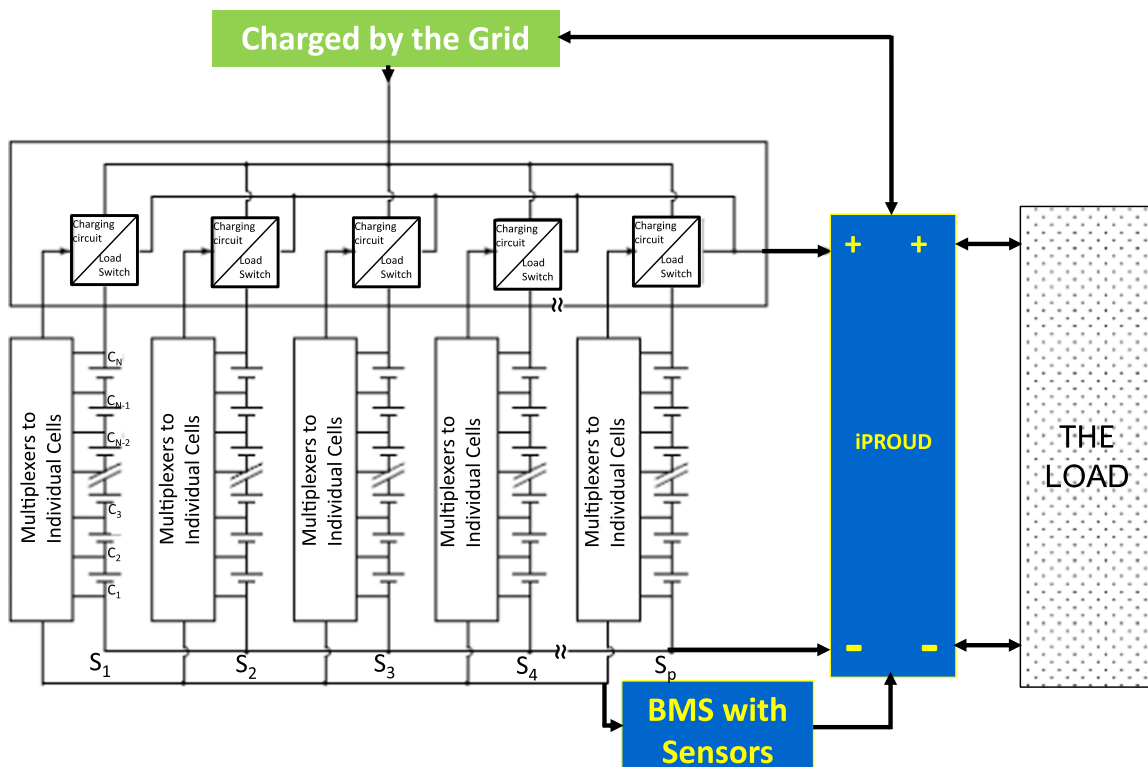

Figure 3. Schematic of an intelligent power routing device (iPROUD) working in tandem with a BMS to estimate the state of readiness of every cell in the battery and then make decisions on the battery’s capabilities to support fluctuating power demands and to receive energy from the grid.

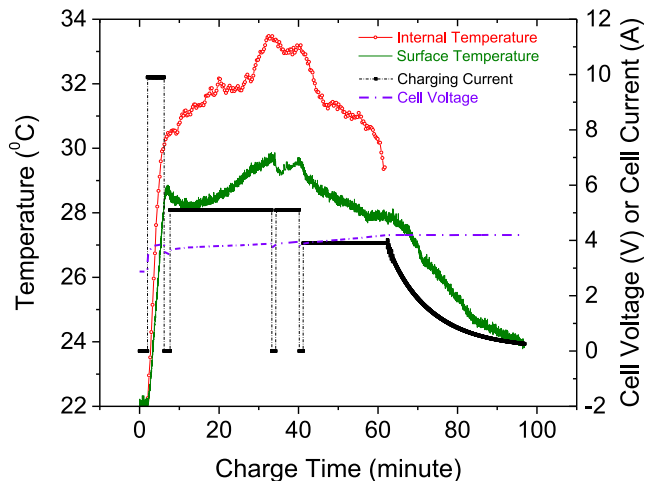

Figure 4. A 25% charging time reduction is achieved while limiting cells’ internal temperature (T_{int}) and using it as one of the control parameters during charging. In the example shown, a 5.3 Ah cell is charged at faster than recommended rate while limiting T_{int} to $<35^{\circ}\text{C}$ and cell voltage to 4.2 V.

detrimental. The data in Fig. 4 is from one cell (5.3-Ah) in a battery being charged initially at nearly 2 C rate. The cell in this example is usually charged at 0.7 C rate, and it takes approximately 120 min to reach full charge after a complete discharge. The iPROUD in this example switched the current to zero when T_{int} increased above 35°C , allowing the cell’s interior to cool, and limited the charging rate to 0.7 C and 0.5 C at other times. The total time to completely charge the battery was still 95 min. In contrast, if the cell surface temperature was selected as a parameter and its limit set to 35°C for switching off the current, then T_{int} would have increased to a much higher value, leading at best to accelerated cell aging, and to TR at worst.

The example of using T_{int} and cell voltage as control parameters by iPROUD could be extended by including the cell’s electrolyte and charge-transfer resistance, and coulombic capacity in order to improve battery management for higher safety, longevity, and efficiency in energy storage and power delivery.

Conclusions

Li-ion batteries are currently the most efficient energy-storing and power-delivering electrochemical system. They are also some of the most challenging systems to manage, especially from a thermal safety perspective. Market demands are driving Li-ion cell and battery manufacturing at an ever-increasing rate, with more equipment experiencing larger fires due to battery failure. To prevent fires, Li-ion batteries rely on a BMS. Most BMS designs for Li-ion batteries are fashioned after those used in the past in NiCd, NiMH, lead-acid and other aqueous batteries, where TR due to a vented, flammable electrolyte was not a risk. Yet, the mechanisms by which fires occur in Li-ion batteries are quite different, therefore BMS designs that were suitable for aqueous batteries are not applicable to predict evolving internal changes in Li-ion cells. Advanced technologies required for Li-ion-specific and safety-centric BMS designs are already available. Industry and users alike need to recognize these facts and adapt today’s sensor technologies and accumulated scientific knowledge to safely manage modern electrochemical systems such as Li-ion batteries.

Acknowledgments

RS acknowledges JHUAPL Janney Energize award used in preparation of this manuscript. SS expresses his thanks to the Vehicle Technologies Office, Office of Energy Efficiency and Renewable Energy, U.S. Department of Energy under contact number WBS1.1.2.406 for supporting this study. The U.S. Government retains and the publisher, by accepting the article for publication, acknowledges that the U.S. Government retains a nonexclusive, paid up, irrevocable, worldwide license to publish or

reproduce the published form of this work, or allow others to do so, for U.S. Government purposes.

ORCID

Rengaswamy Srinivasan  <https://orcid.org/0000-0003-2005-6637>
 Plamen A. Demirev  <https://orcid.org/0000-0003-4099-1534>
 Judith A. Jeevarajan  <https://orcid.org/0000-0003-4843-7597>

References

- <https://prnewswire.com/news-releases/idtechx-forecast-li-ion-demand-to-grow-almost-10-fold-from-2020-2030-but-can-supply-meet-this-demand-301034357.html> (2020), <https://prnewswire.com/news-releases/idtechx-forecast-li-ion-demand-to-grow-almost-10-fold-from-2020-2030-but-can-supply-meet-this-demand-301034357.html> (Last accessed in October 2020).
- J. Kasnatscheew, R. Wagner, M. Winter, and I. Cekic-Laskovic, *Top. Curr. Chem. (Z)*, **376**, 16 (2018).
- R. Chen, Q. Li, X. Yu, L. Chen, and H. Li, *Chem. Rev.*, **120**, 6820 (2020).
- A. F. Blum and R. T. Long Jr. (ed.), *Fire Hazard Assessment of Lithium Ion Battery Energy Storage Systems* (Springer, New York) (2016).
- A. Mauger and C. M. Julien, *Ionics*, **23**, 1933 (2017).
- J. Diekmann, M. Grütze, T. Loellhoeffel, M. Petermann, S. Rothermel, M. Winter, S. Nowak, and A. Kwade, "Potential dangers during the handling of lithium-ion batteries." *Recycling of Lithium-Ion Batteries, Sustainable Production, Life Cycle Engineering and Management*, ed. A. Kwade and J. Diekmann (Springer, Berlin) p. 39 (2018).
- J. Duan, X. Tang, H. Dai, Y. Yang, W. Wu, X. Wei, and Y. Huang, *Electrochemical Energy Reviews*, **3**, 1 (2019).
- Z. Liao, S. Zhang, K. Li, G. Zhang, and T. G. Habetler, *J. Power Sources*, **436**, 226879 (2019).
- P. Sun, X. Huang, R. Bisschop, and H. Niu, *Fire Technol.*, **56**, 1361 (2020).
- T. M. Bandhauer, S. Garimella, and T. F. Fuller, *J. Electrochem. Soc.*, **158**, R1 (2011).
- A. Zhoujian, J. Li, D. Yong, D. Chao, and L. Xuejiao, *J. Therm. Sci.*, **26**, 391 (2017).
- Y. Gao, J. Jiang, C. Zhang, W. Zhang, Z. Ma, and Y. Jiang, *J. Power Sources*, **356**, 103 (2017).
- G. Pistoia and B. Liaw (ed.), *Behaviour of Lithium-Ion Batteries in Electric Vehicles: Battery Health, Performance, Safety, and Cost* (Springer International Publishing AG, Cham, Switzerland) (2018).
- L. Shui, F. Chen, A. Garg, X. Peng, N. Bao, and J. Zhang, *Structural and Multidisciplinary Optimization*, **58**, 331 (2018).
- H. Meng and Y.-F. Li, *Renew. Sust. Energy Rev.*, **116**, 109405 (2019).
- M. Shen and Q. Gao, *Int. J. Energy Res.*, **43**, 5042 (2019).
- K. Liu, K. ii, Q. Peng, and C. Zhang, "A brief review on key technologies in the battery management system of electric vehicles." *Front. Mech. Eng.*, **14**, 47 (2019).
- M. Spielbauer, P. Berg, M. Ringat, O. Bohlen, and A. Jossen, *J. Energy Storage*, **26**, 101039 (2019).
- L. H. J. Rajimakers, D. L. Danilov, R.-A. Eichel, and P. H. L. Notten, *Appl. Energy*, **240**, 918 (2019).
- A. Pesaran and C. Yang, *Presented at 33rd Annual International Battery Seminar and Exhibit: Battery Safety: Innovations to Improve Lithium Battery Safety from Cell to Systems*, Ft. Lauderdale FL, NREL/PR-5400-66206 (2016).
- Q. Li, C. Yang, S. Santhanagopalan, K. Smith, J. Lamb, L. A. Steele, and L. Torres-Castro, *J. Power Sources*, **429**, 80 (2019).
- W. Li, H. Wang, Y. Zhang, and M. Ouyang, *J. Energy Storage*, **24**, 100775 (2019).
- A. Jain, G. Hautier, S. P. Ong, S. Dacek, and G. Ceder, *Phys. Chem. Chem. Phys.*, **17**, 5942 (2015).
- M.-K. Tran and M. Fowler, *Batteries*, **6**, 1 (2020).
- C. Qi et al., *J. Loss Prevention in the Process Industries*, **49**, 603 (2017).
- Safety, operation and performance of grid-connected energy storage systems: Recommended practice* (DNV GL, Akershus, Norway) DNVGL-RP-0043, (2017).
- D. Li, Z. Zhang, P. Liu, and Z. Wang, *Energies*, **12**, 2977 (2019).
- T. Kim, D. Makwana, A. Adhikaree, J. S. Vagoda, and Y. Lee, *Energies*, **11**, 125 (2018).
- Z. Gao, C. S. Chin, J. H. K. Chiew, J. Jia, and C. Zhang, *Energies*, **10**, 1503 (2017).
- X. Feng et al., *Appl. Energy*, **246**, 53 (2019).
- A. Börger, J. Mertens, and H. Wenzl, *J. Energy Storage*, **24**, 100649 (2019).
- W. Li, J. Zhu, Y. Xia, M. B. Gorji, and T. Wierzbicki, *Joule*, **3**, 2703 (2019).
- J. Hong, Z. Wang, and P. Liu, *Energies*, **10**, 919 (2017).
- J. Son and Y. Du, *Processes*, **7**, 38 (2019).
- E. Darcy, J. Darst, W. Walker, D. Finegan, and P. Shearing, *Presented at the JRC Exploratory Research Workshop Petten*, Netherlands (2018).
- A. Pesaran, S. Santhanagopalan, C. Yang, M. Keyser, and Q. Li, *Presented at the 8th Annual Conference on Battery Safety*, Arlington VA (2017).
- J. Duan, X. Tang, H. Dai, Y. Yang, W. Wu, X. Wei, and Y. Huang, *Electrochemical Energy Reviews*, **3**, 1 (2020).
- K. Murata and M. Ota, *J. Energy Storage*, **20**, 576 (2018).
- S. Zheng, L. Wang, X. Feng, and X. He, *J. Power Sources*, **378**, 527 (2018).
- S.-M. Bak et al., *ACS Appl. Mater. Interfaces*, **6**, 22594 (2014).
- J.-H. Kim, K.-H. Lee, D.-C. Ko, S.-B. Lee, and B.-M. Kim, *J. Mechanical Science and Technology*, **31**, 2505 (2017).
- D. Chen, J. Jiang, G.-H. Kim, C. Yang, and A. A. Pesaran, *Appl. Therm. Eng.*, **94**, 846 (2016).
- H. Sun, X. Wang, B. Tossan, and R. Dixon, *J. Power Sources*, **206**, 349 (2012).
- J. B. Robinson, J. A. Darr, D. S. Eastwood, G. Hinds, P. D. Lee, P. R. Shearing, O. O. Taiwo, and D. J. L. Brett, *J. Power Sources*, **252**, 51 (2014).
- T. Yuksel and J. J. Michalek, *Environ. Sci. Technol.*, **49**, 3974 (2015).
- Q. Wang, B. Jiang, B. Li, and Y. Yan, *Renew. Sust. Energy Rev.*, **64**, 106 (2016).
- A. A. Pesaran, S. Santhanagopalan, and G.-H. Kim, *30th Int. Battery Seminar*, PR-5400 (2013).
- M. Keyser et al., *J. Power Sources*, **367**, 228 (2017).
- J. Jaguemont, L. Boulon, and Y. Dubé, *Appl. Energy*, **164**, 99 (2016).
- K. W. E. Cheng, B. P. Divakar, H. Wu, K. Ding, and H. F. Ho, *IEEE Trans. Veh. Technol.*, **60**, 76 (2011).
- P. Zhou, "Electric vehicle thermal management system." US pat. 20100025006A1 (2010).
- <https://insideevs.com/news/341575/tesla-vs-gm-battle-of-the-battery-electronics-cooling-systems/> Last accessed July 2020.
- V. Ruiz, A. Pfrang, A. Kriston, N. Omar, P. Van den Bossche, and L. Boon-Brett, *Renew. Sustain. Energy Rev.*, **81**, 1427 (2018), (Sec. (Sec. 3.1.6)).
- R. Srinivasan, B. G. Carkhuff, and P. A. Demirev, *IEEE Trans. Ind. Electron.*, **65**, 6497 (2018).
- R. Srinivasan et al., *J. Electrochem. Soc.*, **167**, 020559 (2020).
- T. B. Reddy and D. Linden (ed.), *Linden's Handbook of Batteries* (McGraw-Hill, NY) 4th ed. (2011).
- M. Dioxide and K. V. Kordesch (ed.), *Batteries* (Marcel Dekker, Inc, New York) 1 (1974).
- W. R. Scott and D. W. Rusta, *Sealed-Cell Nickel-Cadmium Battery Applications Manual* (NASA Reference Publication, Springfield, Virginia) 1052 (1979).
- A. H. Zimmerman, *Nickel-Hydrogen Batteries: Principles and Practice* (AIAA; Illustrated Edition, Reston, Virginia) (2009).
- J. Jeevarajan, "Battery safety." *Space Systems Safety Design*, ed. A. Larsen and G. Musgrave (Elsevier, Amsterdam) Chap. 17 (2007).
- "Conductive Device." *US Patent*, 2,258,958 (13 July, 1939).
- "Positive thermal coefficient (PTC) Polymer Composition and Resettable Fuse Made Therefrom." *US Patent Application*, #20060081821A1 (20 April, 2006).
- H. Vaidyanathan, H. Wajsgas, and R. Gopalakrishna, *J. Power Sources*, **58**, 1 (1996).
- F. Cohen and P. Dalton, *J. Propul. Power*, **12**, 886 (1996).
- L. Lu, X. Han, J. Li, J. Hua, and M. Ouyang, *J. Power Sources*, **226**, 272 (2013).
- M. Lelie, T. Braun, M. Knips, H. Normann, F. Ringbeck, H. Zappen, and D. U. Sauer, *Appl. Sci., (MDPI)*, **8**, 534 (2018).
- M. U. Ali, A. Zafar, S. H. Nengroo, S. Hussain, M. J. Alvi, and H.-J. Kim, *Energies*, **12**, 446 (2019).
- J. Jeevarajan, "Safety of commercial lithium-ion cells and batteries." *Lithium-ion Batteries—Advances and Applications*, ed. G. Pistoia (Elsevier, Amsterdam) Chap. 17 (2014).
- V. Challa, M. A. Howard, S. A. Binfield, and L. E. Weinstein, "Failure analysis (quality, design assessment, and root cause analysis of batteries)." *Linden's Handbook of Batteries* (McGraw-Hill Education Series, New York) 5th ed., Chap. 32 (2019).
- AIAA S-136 Li-ion battery safety standards document*; (2020); ; NAVSEA 9310; and NASA JSC 20793D.
- R. Srinivasan, A. C. Baisden, B. G. Carkhuff, and M. H. Butler, *J. Power Sources*, **262**, 93 (2014).
- M. Butler, "The van allen probes lithium ion battery performance." *AIAA Propulsion and Energy Forum, 2018 International Energy Conversion Engineering Conference*, Cincinnati, OH (July 9–11, 2018).
- E. J. Nemanick, "Effect of cell reversal on Li-ion batteries." *International Battery Seminar & Exhibit* (2016) www.internationalbatteryseminar.com/battery-safety/16/.
- M. Matsushita, "Experimental observations of aggregation." *The Fractal Approach to Heterogeneous Chemistry*, ed. D. Avnir (Wiley, NY) p. 161 (1989).
- M. Itagaki, K. Honda, Y. Hoshi, and I. Shitanda, *J. Electroanal. Chem.*, **737**, 78 (2015).
- S. Koch, A. Fill, and K. P. Birke, *J. Power Sources*, **398**, 106 (2018).
- P. T. Coman, S. Matefi-Tempfli, C. Veje, and R. E. White, *J. Electrochem. Soc.*, **164**, A1858 (2017).
- M. Ottaway, *Lithium Battery Safety and Calorimetry: Thermal Hazard Technology, AW Briefing, Slide # 13* (2015).
- R. Srinivasan, B. G. Carkhuff, M. H. Butler, and A. C. Baisden, *Electrochim. Acta.*, **56**, 6198 (2011).
- R. Srinivasan, *J. Power Sources*, **198**, 351 (2012).
- R. R. Richardson, "Impedance-based battery temperature monitoring." *Doctor of Philosophy dissertation*, Department of Engineering Science, Balliol College, University of Oxford, (Oxford OX1 3BJ, UK) (2016).
- J. P. Schmidt, S. Arnold, A. Loges, D. Werner, T. Wetzel, and E. Ivers-Tiffée, *J. Power Sources*, **243**, 110 (2013).
- N. S. Spinner, C. T. Love, S. L. Rose-Pehrsson, and S. G. Tuttle, *Electrochim. Acta*, **174**, 488 (2015).
- J. G. Zhu, Z. C. Sun, X. Z. Wei, and H. F. Dai, *J. Power Sources*, **274**, 990 (2015).
- C. Zhang, K. Li, and J. Deng, *J. Power Sources*, **302**, 146 (2016).
- L. H. J. Rajimakers, D. L. Danilov, J. P. M. van Lammeren, T. J. G. Lammers, H. Jan Bergveld, and P. H. L. Notten, *IEEE Trans. Ind. Electron.*, **63**, 3168 (2016).
- P. T. Coman, S. Rayman, and R. E. White, *J. Power Sources*, **307**, 56 (2016).
- R. R. Richardson, S. Zhao, and D. A. Howey, "On-board monitoring of 2-D spatially-resolved temperatures in cylindrical lithium-ion batteries: Part II. State estimation via impedance-based temperature sensing." *J. Power Sources*, **327**, 726 (2016).

89. 'bq26231: Low-cost battery coulomb counter,' Texas Instruments <https://www.ti.com/product/BQ26231>.
90. C. T. Love and K. Swider-Lyons, "Battery health monitoring system and method." US pat. No. 9,465,077 (2016).
91. Y Fernandes, A Bry, and S de Persis, *J. Power Sources*, **389**, 106 (2018).
92. R. Srinivasan, P. A. Demirev, and B. G. Carkhuff, *J. Power Sources*, **405**, 30 (2018).
93. <https://arpa-e.energy.gov/?q=arpa-e-programs/amped> (last accessed: August 2020).
94. R. Srinivasan and L. Srinivasan, "Intelligent power routing device." US pat. 10,224,715B2 (2019).